

Business Logo Sign Details

Mainline

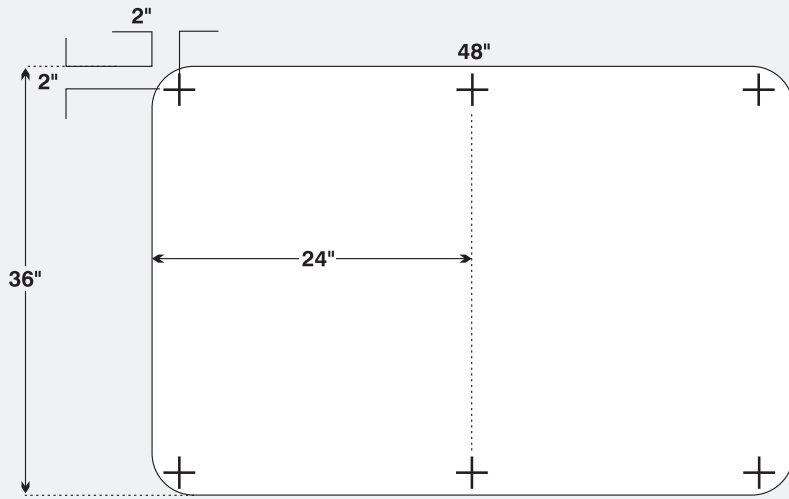

Ramp/Trailblazer

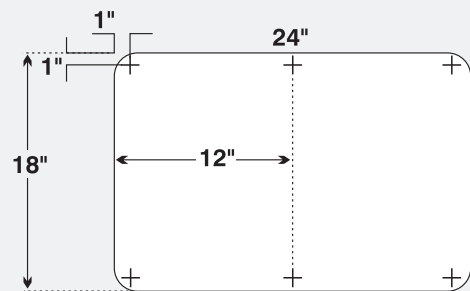

Mainline, Ramp and Trailblazer Business Plaques

The mainline, ramp and trailblazer business plaques shall be fabricated from a single sheet of .080" thickness, 5052H38, 5154-H38 or 6061-T6 aluminum. The aluminum shall be treated before applying the reflective sheeting in accordance with the SCDOT Standard Specifications.

Reflective Sheeting

Type III Encapsulated Lens Sheeting (High Intensity) shall be applied with mechanical equipment in accordance with the manufacturers' specifications.

Logo Art Designs

All logo art designs must be approved by SCDOT and/or South Carolina Logos, Inc. The minimum recommended letter size for mainline business plaque is 10" and 5" for ramp and trailblazer business plaque except that any legend on a symbol or trademark shall be in proportion to the size of the symbol or trademark. When symbols or trademarks are used the mainline business plaque should have a 3/4" margin and the ramp and trailblazer business plaques should have a 3/8" white reflectorized (margin).